

CASTLOADERS



USA



DIMENSIONS AND LOADING DIAGRAMS

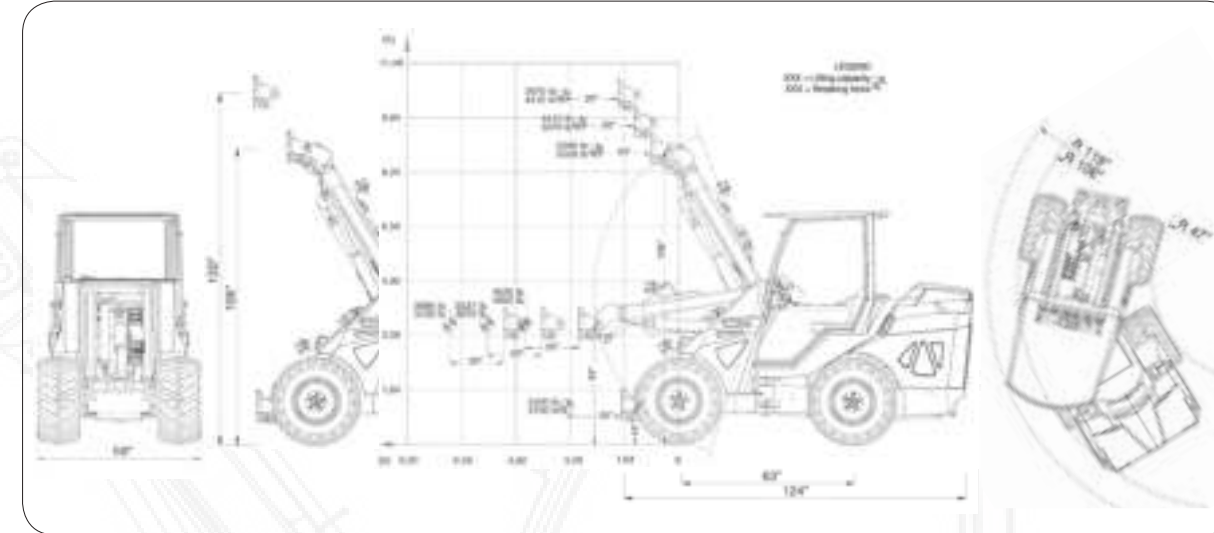

WHEELS

SKID	TRAC MASTER	TRACTOR	TURF
26X12.00-12 31X15.50-15	10PR 33x15.50-50	26X12.00-12 31X15.50-15 33X15.50-15	26X12.00-12 31X15.50-15

THE MAXO SERIES

	LOADING CAPACITY	ENGINE POWER	HYDRAULIC SYSTEM	BOOM HEIGHT
MAXO 57S	4630 lb (with counterweights)	57 Hp / 42 Kw @2600 RPM	21 gal/min	130"
MAXO 57D	4630 lb (with counterweights)	57 Hp / 42 Kw @2600 RPM	21 gal/min	130"



14490 Northdale Blvd
ROGERS, MN 55374
1-833-BUY-CAST
www.tnedistributing.com
info@tnedistributing.com

PEEX, MAXO, USA, 01/2021

Data contained in this document is subject to change without notice and/or modification. Cast Group reserves the right to modify its products without obligation to communications. The images in this document are only a demonstrative purpose.



CASTLOADERS.IT

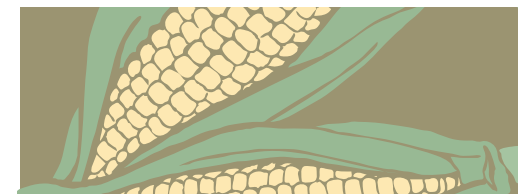



Cast Maxo represents today the flagship model of our production. It is produced in two watercooled versions of 57HP diesel engine which they differ in the speed system. A very powerful and robust machine, suitable for multiple applications, above all in agriculture and construction. All models can be supplied with heated cabin and air conditioning. The 11- function joystick is standard for both Maxo models and is available in ergonomic version as an option.

WORK LIGHTS

High power led work lights.

ROAD LIGHTS

Approved road lights, built with shockproof and anti-wear material.

HOOD

Thermoformed and soundproofed rear hood, with large air vents.

CAB



- Agriculture
- Breeding
- Green maintenance
- Building
- Road maintenance

Compactness and solidity.



Kohler KDI 1903TCR / Stage V diesel engine
 Poclain single speed wheel motors
 Speed 11,18 mph
 Electric differential lock
 Double cylinder hydraulic selflevelling
 12V and 165W power outlet
 Working led lights
 Digital dashboard
 Adjustable ergonomic seat with belt and armrest
 Tractor wheels 31x15.00-50
 408 lb Integrated counterweights
 Weight 5071 lb



Kohler KDI 1903TCR / Stage V diesel engine
 Poclain dual speed wheel motors
 Speed 6,21-11,18 mph
 Electric differential lock
 Double cylinder hydraulic selflevelling
 12V and 165W power outlet
 Working led lights
 Digital dashboard
 Adjustable ergonomic seat with belt and armrest
 Tractor wheels 31x15.00-50
 408 lb Integrated counterweights
 Weight 5181 lb

ALL BLACK EDITION

Maxo All Black Edition is available as an option on all models of the Cast Maxo line. The special finishing is anti-scratch and oil resistant.

A version with an aggressive aesthetic.

Cast Maxo dresses in dark. The All Black Edition version represents the top range and its anthracite gray color with a sand blasted effect finishing, gives a very aggressive look, making it aesthetically very pleasant but especially more resistant to the atmospheric agents, scratches and contact with oils and fuels.

A version for the demanding professional who loves to stand out with a very captivating machine with an undisputed personality.